

Data Bulletin

Direct Current and Photovoltaic Systems Applying Heavy Duty Safety Switches (Fusible and Non-Fusible) on DC and Photovoltaic Systems Class Number 3110

Retain for future use.

GENERAL DC SYSTEMS (for Photovoltaic, see next page)

All heavy duty safety switches with DC ratings (2- and 3-pole fusible and non-fusible) are Underwriters Laboratories® (UL®) Listed for use on DC applications when wired as shown in Figure 1 (A, B, C and D). Additionally:

- Heavy duty safety switches are rated for 600 Vdc maximum open circuit voltage.
- Non-fusible safety switches may carry 100 percent of the nameplate current rating.
- Fusible safety switches may carry 80 percent of nameplate current rating (continuous use).
- Heavy duty switches are dc horsepower rated as indicated on the safety switch wiring diagram.
- Heavy duty switches have a 10,000 amperage dc short-circuit rating unless otherwise stated on the switch wiring diagram.

**Figure 1: General DC Systems
 Fusible and Non-Fusible Wiring Diagram
 (for Photovoltaic, see next page)**

(Non-Fusible Shown)

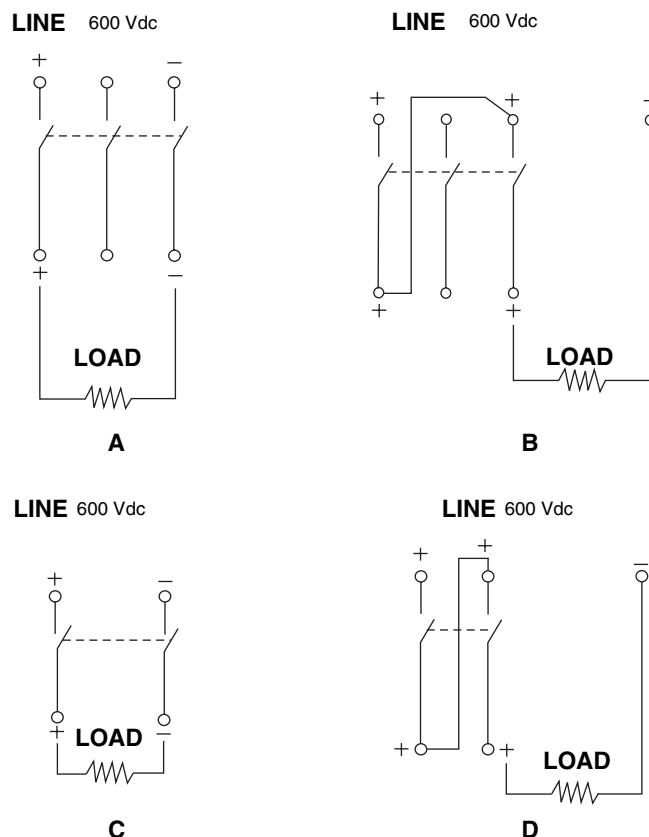

PHOTOVOLTAIC SYSTEMS

NOTE: Heavy duty safety switches may be used on photovoltaic systems with a grounded feed. Refer to Figures 1B, 1D and 2.

Figure 2: Grounded Feed per NEC Article 690

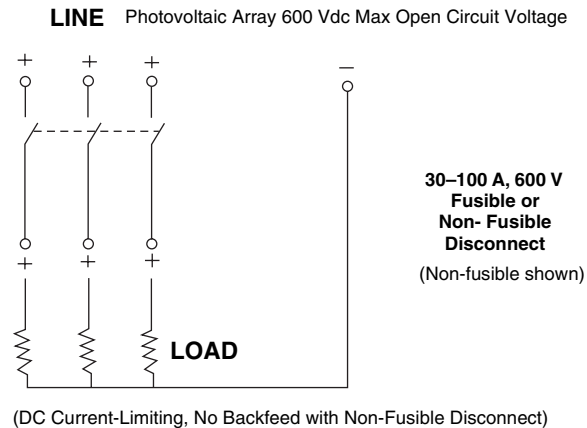

NOTE: Negative grounding shown in Figure above; positive grounded systems are similarly allowed.

Table 1: Limitations

Switch Nameplate Amperage 600 V	Maximum Current for the PV Array or Photovoltaic String	Rated Short-Circuit Current per Pole for the PV Array
30 A	18 A DC per pole	11.5 A (18/1.56)
60 A	60 A DC per pole	38 A (60/1.56)
100 A	100 A DC per pole	64 A (100/1.56)

- If a non-fusible disconnect is used, the inverter must not be capable of backfeeding currents into a short circuit or fault in the photovoltaic array or string.
- One inverter may be connected to each pole of the switch.
- Refer to Table 2 (below) for the lug wire range of heavy duty switches.

Table 2: Heavy Duty Safety Switch Wire Range

Ampere Rating	Conductors per Phase and Neutral	Wire Range of Safety Switch per Phase and Neutral AWG/kcmil *	Wire Range of Lug AWG/kcmil *
30 A	1	#12-6 (Al) or #14-6 (Cu)	#12-2 (Al) or #14-2 (Cu)
	2	#14-10 Cu solid or stranded	#14-10 Cu solid or stranded
60 A	1	#12-3 (Al) or #14-3 (Cu)	#12-2 (Al) or #14-2 (Cu)
100 A	1	#12-1/0 (Al) or #14-1/0 (Cu)	#12-1/0 (Al) or #14-1/0 (Cu)

* 30-100 Amp switches suitable for 60°C or 75°C conductors.

Schneider Electric USA
1601 Mercer Road
Lexington, KY 40511 USA
1-888-SquareD (1-888-778-2733)
www.us.SquareD.com

Electrical equipment should be installed, operated, serviced, and maintained only by qualified personnel. No responsibility is assumed by Schneider Electric for any consequences arising out of the use of this material.

© 2003-2007 Schneider Electric All Rights Reserved

